

2014

**OLIVARI** 

Dal 1911 Olivari realizza maniglie in Italia,  
all'interno dei propri stabilimenti,  
dove si svolge l'intero ciclo produttivo.  
Partendo da barre in ottone, le maniglie vengono  
stampate, lavorate, smerigliate, lucidate,  
cromate e marchiate al laser.

Olivari ha ottenuto le certificazioni  
ISO 9001 e ISO 14001  
e si avvale delle tecnologie più evolute,  
ma ha mantenuto tutta la sapienza artigianale  
accumulata in cento anni di storia.

Since 1911 Olivari has been manufacturing handles  
at its own factories in Italy  
where the entire production process takes place.

Starting with brass billets, the handles are forged, milled,  
polished, buffed, chrome-plated and hallmarked with a laser.  
Olivari has attained ISO 9001  
and ISO 14001 certifications.

Though it uses the most advanced technology,  
Olivari preserves all the artisanal wisdom  
it has accumulated in 100 years of history.

**OLIVARI** 

aprire con decisione  
chiudere lentamente  
open firmly  
close slowly

Patricia Urquiola  
Javier Lopez  
Rodolfo Dordoni  
Penta Associati  
Giorgetto Giugiaro

# Conca

design Patricia Urquiola 2014

*Una maniglia scultorea ed espressiva, ma allo stesso tempo contenuta. Patricia Urquiola gioca con le proporzioni e propone, con Conca, un design tattile: vista di fronte, sembra avere un 'peso' dato dalla sua superficie, che invece si alleggerisce nell'incavo dell'impugnatura.*

*This sculptural lever is eloquent yet understated. Patricia Urquiola experiments with proportions and, with Conca, creates a tactile design. Viewed from the front, it seems to have a certain weight, due to its shell-like surface; instead, the lightness of its concavity is felt in the hand.*

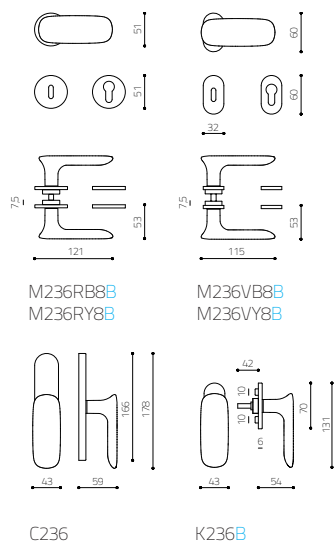

  
ottone/brass



CR cromato/chrome



CO cromato opaco/mat chrome



IS superinox satinato  
superstainlesssteel satined









OLIVARI 







## Patricia Urquiola

Oviedo, 1961

*Nata in Spagna ad Oviedo, studia alla Facoltà di Architettura di Madrid e di Milano, dove si laurea con Achille Castiglioni nel 1989, di cui diventa assistente ai corsi tenuti presso il Politecnico di Milano. Nei primi anni Novanta lavora nell'ufficio tecnico della De Padova, dove entra in contatto con Vico Magistretti. Nel 1996 entra nello studio di Piero Lissoni per collaborare nel settore dedicato al design. Cinque anni dopo apre il suo studio a Milano e si dedica al progetto di interni, allestimento e design. Per Agape, Alessi, B&B, De Padova, Driade, Flos, Foscarini, Kartell, Molteni e Moroso disegna prodotti che rivelano non solo una spiccata sensibilità femminile, ma anche una profonda conoscenza del design di scuola italiana.*

*Born in Oviedo Spain, Urquiola studies at the School of Architecture of Madrid and Milan, where she graduates in 1989 with Achille Castiglioni. She becomes his assistant at courses at the Milan Polytechnic. In the early 1990s she works in the De Padova technical office, where she comes into contact with Vico Magistretti. In 1996 she enters Piero Lissoni's studio collaborating in the design sector. Five years later, she opens her own studio in Milan and devotes herself to designing interiors, installations and objects. She designs products for Agape, Alessi, B&B, De Padova, Driade, Flos, Foscarini, Kartell, Molteni and Moroso. Her work not only reveals a decided feminine sensitivity, but also a profound knowledge of the Italian school of design.*

# Lotus Lotus Q

design Javier Lopez 2014

*Riduzione ed essenzialità nelle linee e negli spessori in Lotus di Javier Lopez. Partendo da un design zen, il giovane architetto si concentra sul dettaglio e "ammorbidisce" leggermente gli spigoli, quel tanto da evitare un'eccessiva severità del progetto.*

*Spare, essential lines and depth of shapes define Lotus by Javier Lopez. Starting with a zen-like design, the young architect focuses on details and 'softens' the angles ever so slightly, just enough to avoid an excess of rigor.*

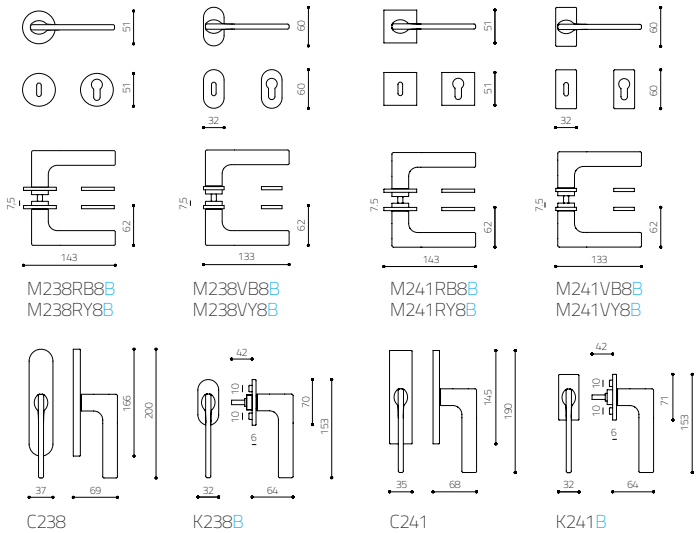

    
ottone/brass

    
ottone/brass

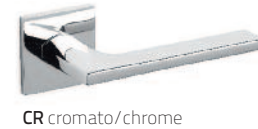











## Javier Lopez

Madrid, 1978

*Javier López nasce in Madrid, Spagna, nel 1978. Dopo aver studiato architettura d'interni e disegno industriale si trasferisce a Milano, collaborando con prestigiosi studi internazionali di design.*

*Nel 2011 apre il suo studio a Milano dove si occupa dalla architettura al disegno di prodotto.*

*Nello stesso anno inizia la sua collaborazione con l'azienda Agape lanciando il suo primo prodotto, "Plus", per il quale è stato nominato al Compasso D'oro ADI 2014.*

*Javier López was born in Madrid, Spain, in 1978. After graduating in interior architecture and industrial design, he moves to Milan, collaborating with various prestigious international design studios. In 2011 he opens his own studio in Milan, where he works on projects from architecture to product design. In the same year he begins working with Agape and launches his first product "Plus", which garners him a nomination for the Compasso d'Oro ADI 2014 Award.*

# Radial

design Rodolfo Dordoni 2014

*Dordoni ripropone il principio dell' integralità e dell' essenzialità, che ha reso la sua maniglia Total un vero bestseller. Se lì il principio erano linee rette e spigoli vivi, in Radial si rivaluta la linea curva, sia nella leva che nella rosetta.*

*Dordoni reinterprets the principles of coherence and simplicity that made his Total door lever a real bestseller. Where it favored straight lines and hard angles, Radial displays a new appreciation for curves, in both the lever and the rosette.*

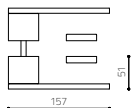
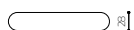

M235RB8  
M235RY8

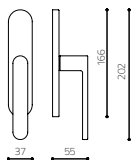

C235

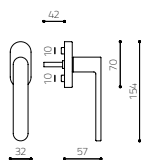

K235



ottone/brass



CR cromato/chrome



CO cromato opaco/mat chrome



IS superinox satinato  
superstainlesssteel satined











OLIVARI 





# Rodolfo Dordoni

Milano, 1954

*Laureato in Architettura a Milano, nel 1979 Dordoni diventa direttore artistico di Cappellini, con cui collabora per dieci anni disegnando pezzi di grande successo come il divano Cuba.*

*È stato responsabile di intere collezioni di prodotti per Artemide, Fontana Arte e Foscarini. Dal 1998 coordina e disegna i prodotti di Minotti e dal 2006 quelli di Roda. Contemporaneamente all'attività di art director disegna sedie, imbottiti, librerie e lampade per Cassina, Driade, Emu, Flos, Flou, Molteni, Moroso, Serralunga e, Venini.*

*Lo studio Dordoni Architetti, fondato a Milano nel 2005, sviluppa progetti di allestimento, interni e architettura.*

*After graduating in architecture in Milan in 1979, Dordoni becomes the artistic director of Cappellini. He works there for ten years, designing highly successful pieces such as the Cuba sofa.*

*He is in charge of entire collections for Artemide, Fontana Arte, and Foscarini. In 1998 he began coordinating and designing products for Minotti, and in 2006 for Roda. While working as art director, he also designed chairs, upholstered furniture, bookcases, and lamps for Driade, Emu, Flos, Flou, Molteni, Moroso, Serralunga, and Venini. The Dordoni Architetti Studio was founded in Milan in 2005 and also develops projects for installations, interiors, and architecture along with its design work.*

# Marbella

design Penta Associati 2014

*Conciliare gli opposti: Marbella si presenta con una "doppia faccia" e gioca sul concetto up and down. In un'elegante semplicità dell'insieme, ad una superficie completamente piana fa da controcanto una bombata, e così si ottiene anche un'ottima ergonomia.*

*A balance of opposites: Marbella reveals its "double face" in a playful approach to the concept of up and down. The overall effect is of elegant simplicity, where a completely flat surface plays counterpoint to a rounded one. The result: excellent ergonomics.*

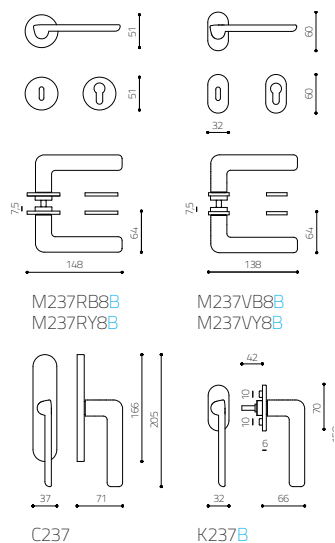

  
ottone/brass



CR cromato/chrome



CO cromato opaco/mat chrome



IS **superinox satinato**  
**superstainlesssteel satined**











OLIVARI 





# Penta Associati

## Penta Associati

1994

*Penta Associati è un team di progettazione composto da cinque professionisti che fin dal 1994 collabora con Olivari per la realizzazione di maniglie caratterizzate da un disegno impeccabile e da una assoluta funzionalità.*

*Penta Associati is a team consisting of five designers who work in strict collaboration with Olivari. Their handles feature a flawless design and absolute functionality.*

# Pitagora Pitagora Q

design Giorgetto Giugiaro 2014

La riedizione di un modello realizzato originariamente in resina e oggi riproposto in metallo. Pitagora esprime l'essenzialità nella progettazione di Giugiaro, con l'incontro tra un cilindro e un parallelepipedo: la forza di un linguaggio tridimensionale che adotta la geometria e lo sviluppo dei solidi come matrice del progetto.

*This lever is the re-issue of a model originally crafted in resin and now interpreted in metal. With the intersection of a cylinder and a cube, Pitagora expresses the minimalist values of Giugiaro's design: the powerful effect of a three-dimensional language that uses geometry and the development of solid shapes as a matrix for the project.*

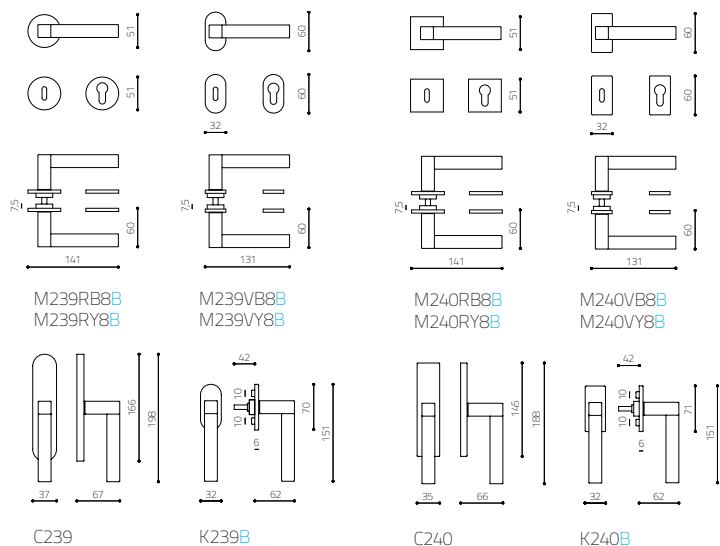

ottone/brass   



CR cromato/chrome



CO cromato opaco/mat chrome



CA cromato-cromato opaco  
chrome-mat chrome



IS superinox satinato  
superstainlesssteel satined

ottone/brass   



CR cromato/chrome



CO cromato opaco/mat chrome



CA cromato-cromato opaco  
chrome-mat chrome



IS superinox satinato  
superstainlesssteel satined









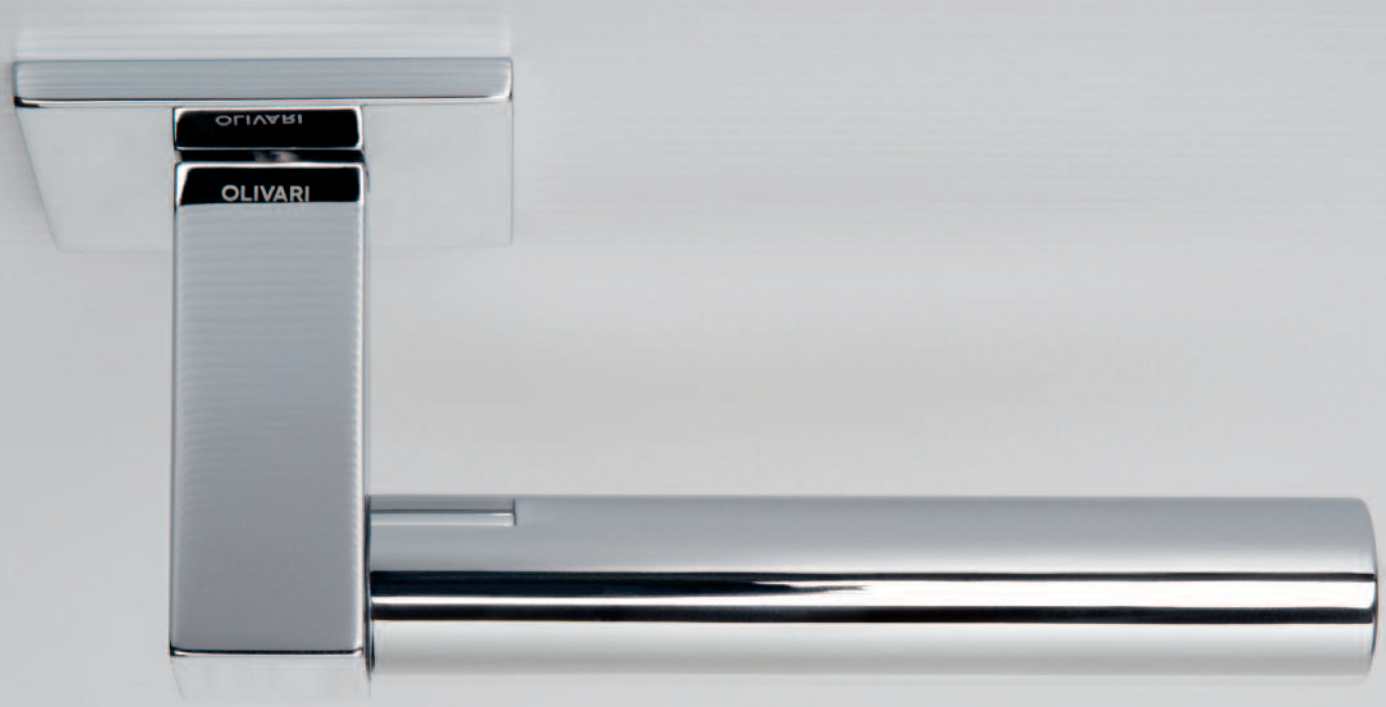



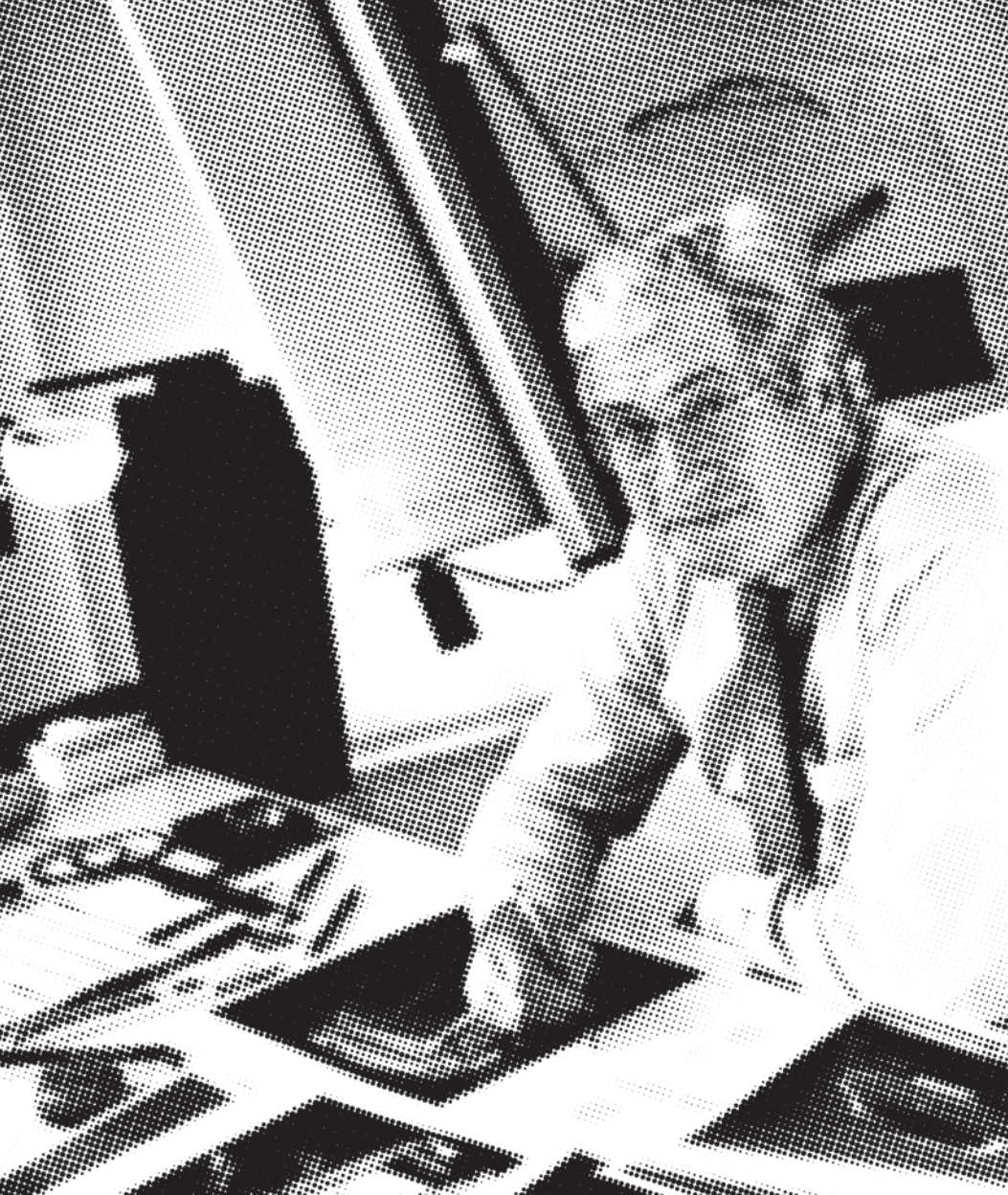

## Giorgetto Giugiaro

Garessio (CN), 1938

*Giovane disegnatore alla Fiat, a soli 21 anni diventa capo dell'ufficio stile della Carrozzeria Bertone, disegnando diversi classici come la Alfa Romeo Giulia GT (1964). Dopo una breve parentesi alla Ghia, nel 1968 è cofondatore della Italdesign, società che offre un servizio di ingegnerizzazione e prototipazione, oltre che di stile. Volkswagen Golf (1974) Lancia Delta (1979) e Thema (1984) Fiat Panda (Compasso d'Oro 1979) Uno (1983) e Punto (1993) Maserati 4200 (2000) Suzuki SX4 (2000) Alfa Romeo Brera (2005) BMW Mini Cabrio (2012) sono alcune tra le più celebri auto di Giugiaro, a cui si aggiungono molti prototipi di ricerca fortemente innovativi. La Italdesign, che oggi conta 800 collaboratori, ha esteso la sua attività anche ai progetti di yacht, autobus, treni.*

*A young designer at Fiat, at 21 Giugiaro becomes the head of the style office in the Bertone Body Shop, designing several classics such as the Alfa Romeo Giulia GT (1964). After a short stint in Ghia, in 1968 he co-founds Italdesign, a company which offers engineering and prototype services as well as styling. The Volkswagen Golf (1974) Lancia Delta (1979) e Thema (1984) Fiat Panda (Compasso d'Oro 1979) Uno (1983) e Punto (1993) Maserati 4200 (2000) Suzuki SX4 (2000) Alfa Romeo Brera (2005) BMW Mini Cabrio (2012), are some of Giugiaro's most famous cars. There are also many prototypes of highly innovative research. Today Italdesign has over 800 collaborators and has extended its business to designing yachts, buses, and trains.*

Il catalogo ed i prodotti sono soggetti ad aggiornamenti.

Modelli e marchi depositati.

Tutti i diritti riservati © Olivari B. s.p.a.

Catalog and products subject to updating.

Registered trademarks and patented designs.

All rights reserved © Olivari B. s.p.a.

#### Concept and graphic

Marco Strina

#### Photo

Sauro Sorana

#### Press Office

Clara Buoncristiani

#### Pre press

Up studio\_Milano

#### Printed in Italy

OGM\_Padova 11.2013

#### Olivari B. spa

Via Giacomo Matteotti, 140  
28021 Borgomanero NO Italy

T +39 0322 835080

F +39 0322 846484

olivari@olivari.it

www.olivari.it





[olivari.it](http://olivari.it)